

CS-PS-DY10: Reci Power Supply for 80 - 90W W2 CO2 Laser Tube

CS-PS-DY13: Reci Power Supply for 100 - 120W W4 CO2 Laser Tube

CS-PS-DY20: Reci Power Supply for 130 - 180W W6 / W8 CO2 Laser Tube

| Overview | Specifications | Packing list | Warranty |
|----------|----------------|--------------|----------|
|----------|----------------|--------------|----------|

Mark & model: DY10 / DY13 / DY20, small size, quick response, it is suitable for Reci W2 / W4 / W6 / W8 laser tube.

Origin: Asia and Pacific Area China

Quality standard: International

H.S. Classification: Machinery & Electronics Electr. Element 8541 Semiconductor devices; light - emitting diodes parts.

We can supply AC110V and AC220V tow style of power source, please tell us your voltage when order and inquiry.

Features

This power supply adopts thin type design. The shape of this power supply is thin which is specially designed for special laser tube. The power supply makes laser tube output larger and more stable.

Quick Response: It can enlarge laser power and prolong laser tube's service life.

Easy Control: The start and stop of laser can be easily controlled by TTL level.

This power supply has output open circuit protection.

This power supply has TTL signal indication, water through signal indication and laser output indication.

This power supply has the BUTTON to test it work properly.

Application: Sculpture and cut acrylic, fabric, double color sheet and rubber, etc



We stick the protection film on the power source to prevent the metal parts of the scrape!

Instruction



Power Supply Indicator Lamp



Power indicator lamp

Test button

Laser indicator lamp

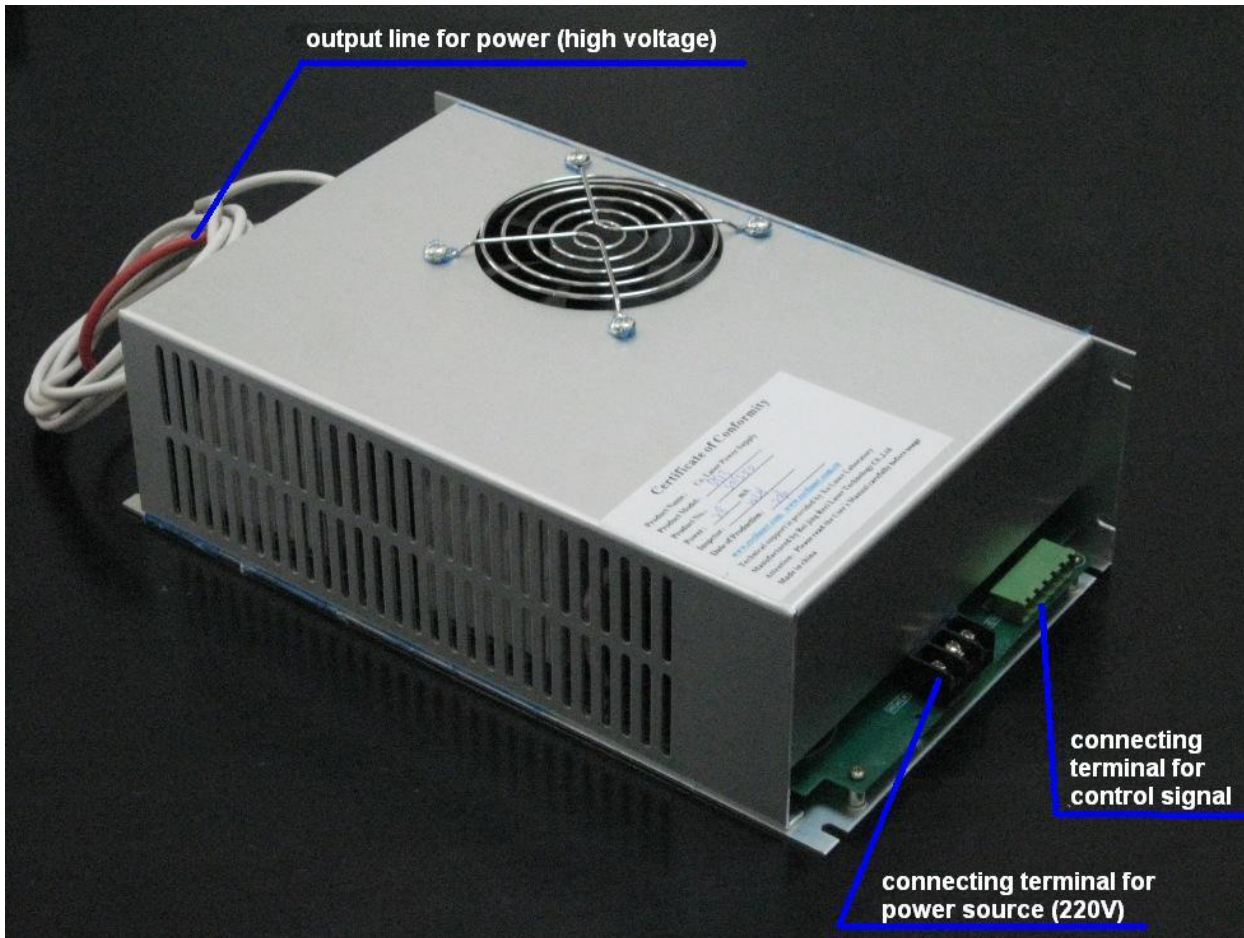

Usage

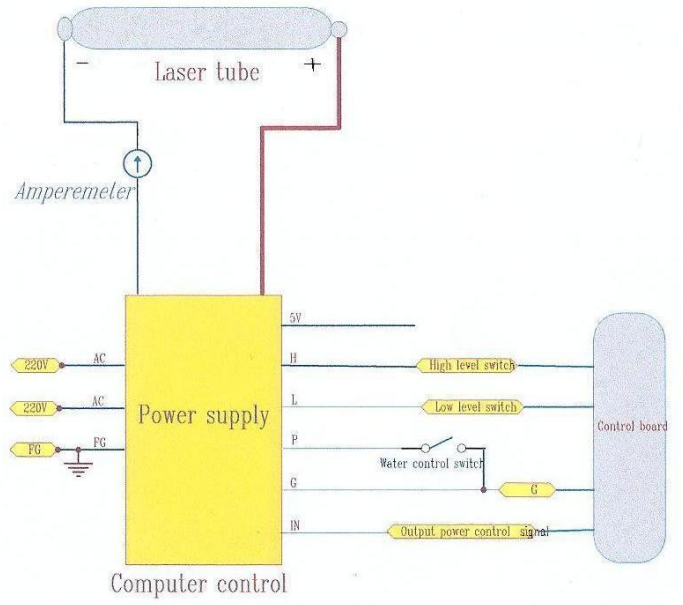
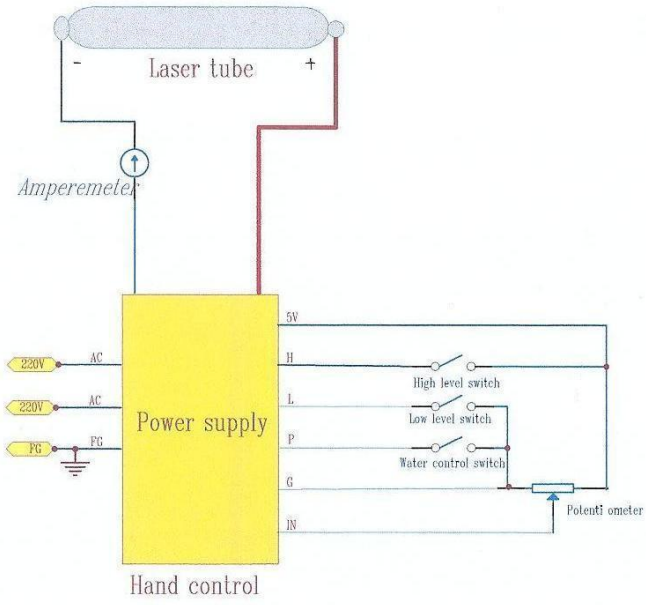



I. Instruction for sub - connection wire of the control end

| | | | | | |
|----|----|----|----|---|----|
| 1 | 2 | 3 | 4 | 5 | 6 |
| 5V | TH | TL | WP | G | IN |

- 1) Footer 1 is 5V power supply. (Not needed when connecting the cardinal plate. It is used when regulating the power with potentiometer and the 5V current should be less than 10 mA.
- 2) TH, TL refers to high and low power level respectively, and WP refers to water protection.
- 3) Footer 5 G refers to ground and 6 refers to input end.
- 4) When connecting the control plate, connect the light signal with footer 2 in the case of high power level light-emitting, (footer 3 for low power level light-emitting), connect the ground-wire with footer 5, connect footer 6 with power control analog signal, and make short circuit for footer 4 and 5.
- 5) PWM can also be used in footer 6, but the pulse peak is required to reach 5V, and the frequency should be above 20K.
- 6) For testing: 3, 4 and 5 are in short circuit (or 4, 5 are in short circuit and 3, 5 are connected to switch), the potentiometer center is connected with 6 IN, and the two other ends are connected to 5V and ground (1 and 5) respectively.
- 7) The high power level controls the light, 1 and 2 are connected, and 4 and 5 are in water protection.
- 8) It is not proposed to control laser power with high-frequency modulation, because it will have impact on the service life of the laser.
- 9) The model is applicable to W2 laser, it is necessary to regulate and use the current according to the laser instructions.
- 10) The ammeter is concatenated to the cathode line.

II. Instruction for power wire

| | |
|--------------------|--|
| Footer 1 Ground | Footer2, Footer3 AC 220V 50HZ (10A) |
|--------------------|--|

Note: The table 10A refers to the connection wire requirement, but not the actual power dissipation.

III. Instruction for laser connection wire

- 1) The positive red - line with high voltage is connected to the laser tail
- 2) The negative white - line is connected to laser output window

IV. Current limitation

To limit the working current, the potentiometer (Lies in the underside of the power supply should be rotated in counterclockwise (Please refer to the schematic diagram in our website). Limit the maximum output current as it is regulated in the operating instruction. The working current should be limited before delivery.

V. Linear scale between input signal and the output current

Turn around the potentiometer; the linear scale will be changed: for example, when the input signal is 0 - 5V, the output current is 0 - 32mA. Or when the input signals 0 - 2V, the output signal is 0 - 32mA.

Note: When the potentiometer is turned down too much, the real output current will be brought down by the same input signal.

VI. Using current

The use standard for our power supply is under 220V, 50Hz. The fluctuation of the input voltage and frequency will affect the working current provided by the power supply, the impact is linear relative. The unstable of the input voltage will affect the output power of the laser tube. The fluctuation of the input voltage has no impact on the lifespan of the laser if only the current provided by the power supply is not over the current limitation.

| Overview | Specifications | Packing list | Warranty |
|----------|----------------|--------------|----------|
|----------|----------------|--------------|----------|

Specifications

| item | | CS-PS-DY10 |
|---------------------|---|---|
| Input | Input Voltage | AC220V or AC110V (The order should be especially instructions) |
| | AC Frequency | 47 - 440Hz |
| | Max Input Power | 450W |
| | Max Input current | 5A |
| Output | Max output Voltage | 35KV |
| | Max Output current | 24mA |
| Efficiency | equal or more than 90% (load down) | |
| Time no-failure | equal or more than 10000h | |
| Response speed | equal or less than 1mS (the time from output of switch signal to 90% of initial setting current) | |
| Voltage - resisting | Input - Output ,input - machine hull: C1500V 10mA 60s; output cathode and machine hull connection | |
| Usage environment | Work temperature (-10 ~ 40) , Relative humidity: Equal or less than 90% | |
| Cooling Type | The compulsive air cooling | |

| item | | CS-PS-DY13 |
|---------------------|---|---|
| Input | Input Voltage | AC220V or AC110V (The order should be especially instructions) |
| | AC Frequency | 47 - 440Hz |
| | Max Input Power | 550W |
| | Max Input current | 8A |
| Output | Max output Voltage | 40KV |
| | Max Output current | 28mA |
| Efficiency | equal or more than 90% (load down) | |
| Time no-failure | equal or more than10000h | |
| Response speed | equal or less than 1mS (the time from output of switch signal to 90% of initial setting current) | |
| Voltage - resisting | Input - Output ,input - machine hull: C1500V 10mA 60s; output cathode and machine hull connection | |
| Usage environment | Work temperature (-10 ~ 40) , Relative humidity: Equal or less than 90% | |
| Cooling Type | The compulsive air cooling | |

| item | | CS-PS-DY20 |
|---------------------|---|---|
| Input | Input Voltage | AC220V or AC110V (The order should be especially instructions) |
| | AC Frequency | 47 - 440Hz |
| | Max Input Power | 1000W |
| | Max Input current | 10A |
| Output | Max output Voltage | 50KV |
| | Max Output current | 35mA |
| Efficiency | equal or more than 90% (load down) | |
| Time no-failure | equal or more than10000h | |
| Response speed | equal or less than 1mS (the time from output of switch signal to 90% of initial setting current) | |
| Voltage - resisting | Input - Output ,input - machine hull: C1500V 10mA 60s; output cathode and machine hull connection | |
| Usage environment | Work temperature (-10 ~ 40) , Relative humidity: Equal or less than 90% | |
| Cooling Type | The compulsive air cooling | |

| Overview | Specifications | Packing list | Instruction | Warranty |
|----------|----------------|--------------|-------------|----------|
|----------|----------------|--------------|-------------|----------|

Terms & Condition of Purchase: After we receive PO from customer with stamp, we give PI for customer.

Lead Time: After receiving customer's deposit, within 1-4 days.

Wooden Box: There is total one carton box.

| | |
|---------------------|---|
| Model | CS-PS-DY10 |
| Power Source Size | 7.8" x 6.4" x 3.1" (198mm x 163mm x 80mm) |
| Power Source Weight | 3.96lb (1.8kg) |
| Package | Carton box |
| Packing Size | 10.4" x 8" x 5.3" (265mm x 205mm x 135mm) |
| Gross Weight | 5.94lb (2.7kg) |

| | |
|---------------------|---|
| Model | CS-PS-DY13 |
| Power Source Size | 10.6" x 6.4" x 3.1" (270mm x 163mm x 80mm) |
| Power Source Weight | 4.62lb (2.1kg) |
| Package | Carton box |
| Packing Size | 13.4" x 9.2" x 6.1" (340mm x 235mm x 155mm) |
| Gross Weight | 7.7lb (3.5kg) |

| | |
|---------------------|--|
| Model | CS-PS-DY20 |
| Power Source Size | 12" x 8" x 3.1" (312mm x 205mm x 80mm) |
| Power Source Weight | 6.9lb (3.14kg) |
| Package | Carton box |
| Packing Size | 16" x 11" x 6.5" (410mm x 280mm x 165mm) |
| Gross Weight | 12.1lb (5.5kg) |

Packing List

Laser power source 1 set

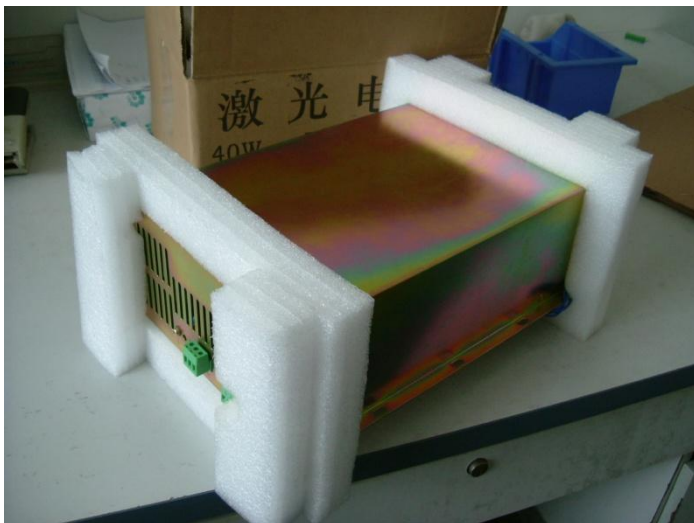

| | | | |
|-----------------|-----------------------|---------------------|-----------------|
| Overview | Specifications | Packing list | Warranty |
|-----------------|-----------------------|---------------------|-----------------|

Quality Assurance

1. The warranty period for the first buyer is 12 months.
2. The quality assurance is invalidated to the special offered products or customized products.
3. Power supply must working under regulated current, otherwise the power supply will not be guaranteed by manufacturer.
4. The returned W - Series products must meet the following qualifications:
 - 1) The appearance, structure and certificate are in good condition.
 - 2) The power supply doesn't be impacted or pressed by external force.

Comprehensive guarantee for one year except the wearing parts
24 - hour technical support by email or calling
User - friendly English manual for machine using and maintaining

Spare Parts Supports

We provide all replacement parts for all machines we sold, if you have a parts that break beyond warranty period, you could order it directly from us at reasonable prices. We would post the new parts with step by step instructions in PDF format on how to replace the parts to you.

If you want to buy any parts from us, please tell us the names or pictures of the parts.

Satisfaction Guarantee

For the items other than consumable products sold via www.Sign-in-China.com, we provide 12 months warranty after shipment. All the extra parts for equipment can be purchased from www.Sign-in-China.com. Further, for our VIP customers, the period of warranty shall be extended to 18 months.

We offer 14 days 100% satisfaction guarantee on all our machines. If you are not satisfied after receiving an item, Sign-in-China.com promises that, within 14 days after actual delivery of such an item, you are allowed to return the item to us and get complete refund, provided the returned item does not affect its subsequent re - selling and you also undertake the charge of returning delivery.

More information, please look at the document of [Training & Warranty & Service Policies](#).